

# MM G520.250

---



## CONTENT

---

|  |          |  |           |
|--|----------|--|-----------|
| <b>1 Introduction</b> .....                  | <b>2</b> | 2.3 Cable Connection.....                              | 9         |
| 1.1 Advantages.....                          | 2        | 2.4 Mounting Drive Unit Casing.....                    | 10        |
| 1.2 Scope of Application.....                | 2        | 2.5 Chain Wheel Parts Installation.....                | 12        |
| 1.3 Product Naming Protocol.....             | 2        | 2.6 Crank Installation.....                            | 12        |
| 1.4 Drive Unit Appearance.....               | 3        | 2.7 External Speed Sensor Installation SR SD02.01..... | 13        |
| 1.5 Drive Unit Structure and Dimensions..... | 4        | <b>3 List of Materials.....</b>                        | <b>16</b> |
| 1.6 Main Technical Parameters.....           | 5        | 3.1 Drive Unit - MM G520.250.....                      | 16        |
| <b>2 Drive Unit Installation.....</b>        | <b>6</b> | 3.2 Cables.....  | 17        |
| 2.1 List of Tools to be used.....            | 6        | Notes.....   | 18        |
| 2.2 Mounting Drive Unit.....                 | 7        |  |           |

# 1 INTRODUCTION

## 1.1 Advantages

With a maximum torque output of 95Nm the new M500 mid drive system is designed for sporty, powerful riding in any terrain. For hard-tail or sull suspension MTB designs. Lightweight and compact at less than 3.3 kg.

## 1.2 Scope of Application

The drive unit works properly in the following environmental conditions:

- Ambient temperature: -20 to + 55°C ;
- Relative humidity: 15–95 % RH;



The function of the product is impaired by the presence of any major caustic gas, any medium that affects the product's electrical insulation properties or any high-intensity magnetic field.

## 1.3 Product Naming Protocol

There is a badge on the housing, showing information as follows:

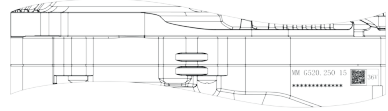

MM G520. 250 15 033 F5 S329 0001  
A B C D E F G H

- A MM: Mid motor
- B G520: Motor model
- C 250: Rated motor power
- D 15: Number of winding turns
- E 033: Connection combination sort
- F F5: Measurement and control equipment number
- G S329: Date of manufacture, indicating it is manufactured on March 29, 2018
- H 0001: Production serial number, ranging from 0000 to 9999; 0001 is the production serial number of the first motor

## 1.4 Drive Unit Appearance



Motor with connection interface integrated with battery



Motor with normal connection interface

## 1.5 Drive Unit Structure and Dimensions

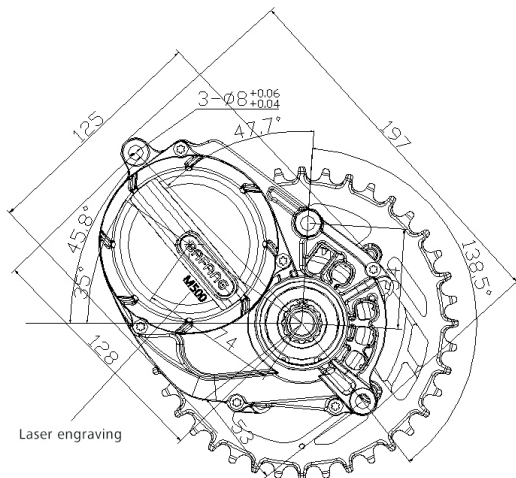
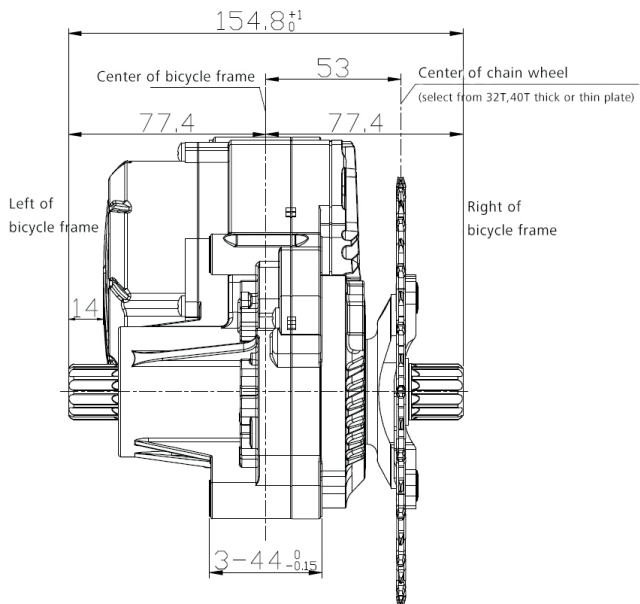







## 1.6 Main Technical Parameters

|                            |  |      |      |
|----------------------------|--|------|------|
| Rated voltage (V)          | 36   | 43   | 48   |
| Rated power (W)            | 250  |      |      |
| Rated efficiency (%)       | ≥80%   |      |      |
| Rated rotating speed (rpm) | 94±6   | 99±6 | 94±6 |
| Maximum torque (Nm)        | ≥95  |      |      |
| Chain wheel                | single 32T/ single 40T   |      |      |
| Optional chain guard       | /  |      |      |
| Weight (Kg)                | 3.3(aluminium)   |      |      |
| Sensors                    | pedal assist sensor (torque speed) , bicycle wheel speed sensor and temperature sensor   |      |      |
| Noise (dB)                 | ≤55  |      |      |
| Water-proof grade          | IP66   |      |      |
| Certification              | CE / EN14766 / RoHS  |      |      |
| Operating environment      | -20 C ~55 C  |      |      |
| Functions                  | Light function: DC 6V/3W<br>headlight & rearlight<br>Optional functions: Bluetooth module, gear sensor, reprogramming function |      |      |

# 2 DRIVE UNIT INSTALLATION

## 2.1 List of Tools to be used

| Use of the Tools  | Tools  |
|---|--|
| Bolts for connection of the motor to the connection interface |  Internal hexagonal wrench  |
| Nuts for connection the motor to the connection interface     |  External hexagonal sleeve  |
| Tightening and loosening the lock ring of the chain wheel     | Dedicated tools  |
| Chain stand, chain stand screws                               |  T20 Torx screw driver      |
| Covering case   |  T10 Torx screw driver      |
| Bash guard  |  Internal hexagonal wrench  |
| Crank mounting screw  |  Internal hexagonal wrench |
| Connectors  | Dedicated tools  |

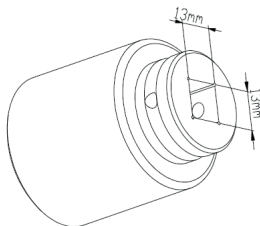

Dedicated tool for lock ring of the chain wheel

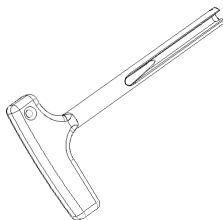



Dedicated tool for connectors

## 2.2 Mounting Drive Unit

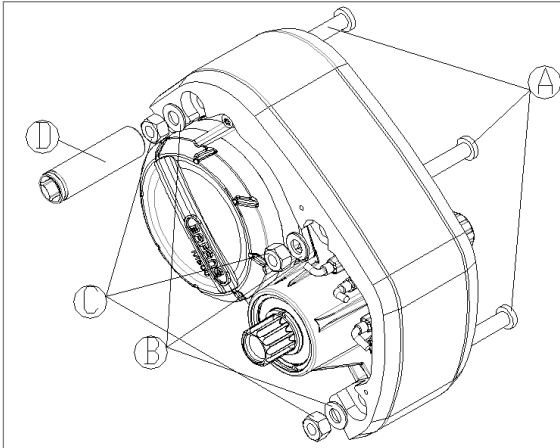
### 2.2.1 Install motor to normal connection interface



-   
- A** M8 bolt  
140128000002
- B** M8 flat washer  
1401060000196
- C** M8 Lock ring  
1401080000127
- D** Standard tool

1) Align the 3 mounting holes of the motor with the mounting holes of the connection interface of the bicycle frame, insert the 3 dedicated M8 bolts into the three mounting holes from the right side of the bicycle frame, and pass through the motor and come out from the left side of the bicycle frame.

2) Tighten the 3 sets of M8 standard locking hex nuts (13\*13) and washers with the bolts on the left side of the bicycle frame, and lock them with the common tools as shown in the Figure with the tightening torque of 35N.m.

The size of the common tools made by the manufacturer:

Outside diameter is 17.7 mm and length is 63 mm.

Requirements for the tools:

Outside diameter is less than 20 mm and length is greater than 35 mm.

## 2.2.2 Install motor to connection interface integrated with battery

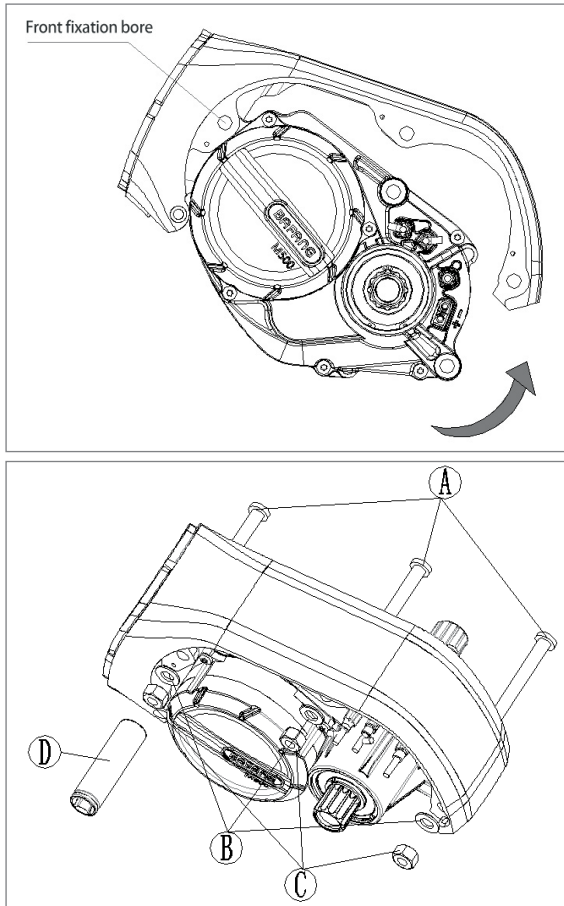

- A M8 bolt  
1401280000002
- B M8 flat washer  
1401060000196
- C M8 Lock ring  
1401080000127
- D Standard tool

1) Firstly, align the front M8 screw hole of the motor shown in figure 1 to the front fixation bore of the interface, and then make this bore as the axis, turn the motor clockwise to align the other two mounting holes. insert the 3 dedicated M8 bolts into the three mounting holes from the right side of the bicycle frame, and pass through the motor and come out from the left side of the bicycle frame.

2) Tighten the 3 sets of M8 standard locking hex nuts (13\*13) and washers with the bolts on the left side of the bicycle frame, and lock them with the common tools as shown in the Figure with the tightening torque of 35N.m.



The size of the common tools made by the manufacturer:

Outside diameter is 17.7 mm and length is 63 mm.

Requirements for the tools:

Outside diameter is less than 20 mm and length is greater than 35 mm.

## 2.3 Cable Connection

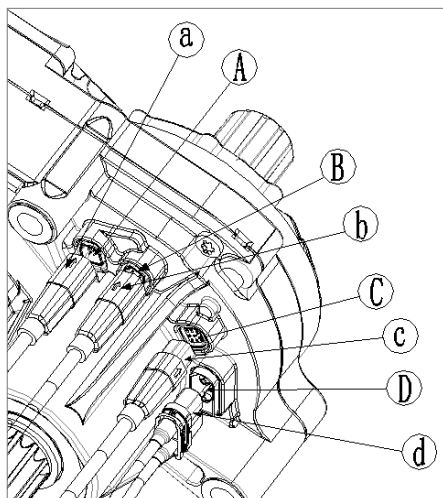

- Ⓐ Male eight-pin connector at the motor
- ⓐ Female eight-pin connector at the front BUS cable
- Ⓑ Male six-pin connector at the motor
- ⓑ Female six-pin connector for other device
- Ⓒ Female eight-pin connector at the motor
- ⓒ Male eight-pin connector rear BUS cable
- Ⓓ Male connector for power supply at the motor
- ⓓ Female connector for power supply at the battery

First, plug a into A and then plug c into C. At last, plug d into D. (The step to plug b into B depends on customer's requirement for function.)

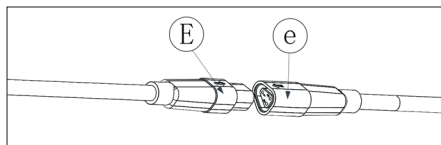

- Ⓔ Male three-pin connector at the battery
- ⓔ Female three-pin connector at BUS cable

Plug connector e from BUS cable to connector E from battery for communication.

## 2.4 Mounting Drive Unit Casing

### 2.4.1 Install bash guard and cover of normal version

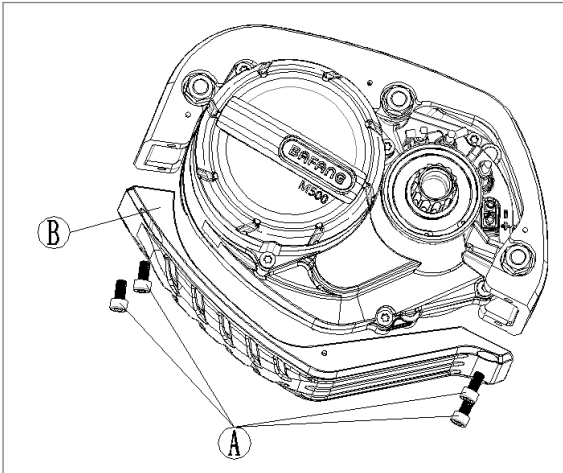

- A Hexagonal socket head cap screw M5\*8
- B Bash guard

Use internal hexagonal wrench to tighten 4 M5\*8 screws through hole sites on the bash guard to the connection interface, with tightening torque at 4 N.m.

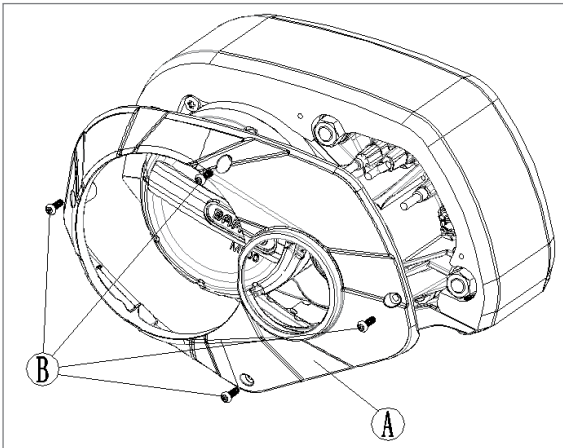

- A Covering case
- B Hexalobular socket pan head screw M3\*8

Use T10 Torx screw driver to tighten 4 M3\*8 screws through hole sites on the covering case to the connection interface and bash guard, with tightening torque at 1 N.m.

## 2.4.2 Install bash guard and cover of battery integrated version

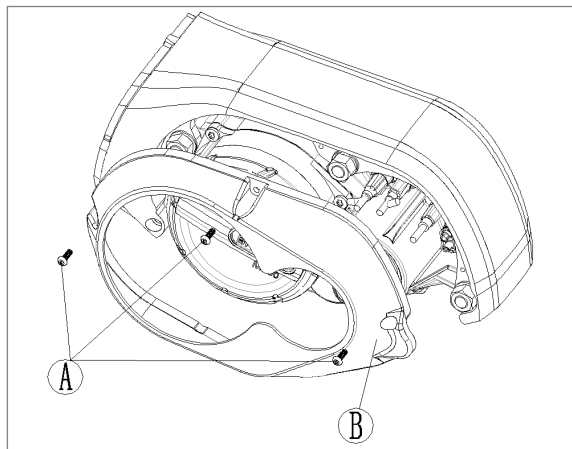

A Hexalobular socket pan head screw M3\*8

B Covering case

Use T10 Torx screw driver to tighten 3 M3\*8 screws through hole sites on the covering case to the connection interface and bash guard, with tightening torque at 1 N.m.

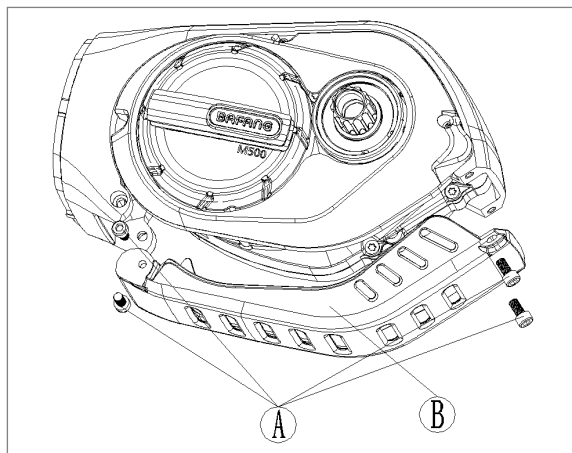

A Hexagonal socket head cap screw M5\*8

B Bash guard

As shown in the figure, use internal hexagonal wrench to tighten 2 M5\*8 screws through hole sites on the bash guard to the connection interface(right side as shown in the figure), with tightening torque at 4 N.m. Then, use internal hexagonal wrench to tighten 2 M5\*8 screws through hole sites on the connection interface to the bash guard(left side as shown in the figure), with tightening torque at 4 N.m.

## 2.5 Chain Wheel Parts Installation

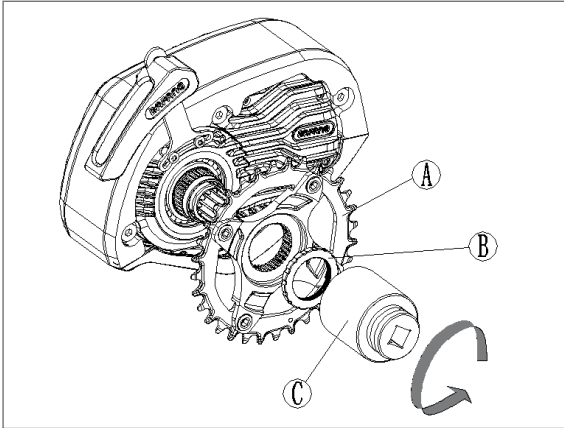

- A Chain wheel (Chain wheel shall be made according to orders of the customers)
- B Lock ring
- C Dedicated tool

Align the splined teeth of the chain wheel with the splined teeth of the axle in motor, and insert the chain wheel, then use the tool to tighten the lock ring to the motor in a counterclockwise direction at the tightening torque of 35N.m.

## 2.6 Crank Installation

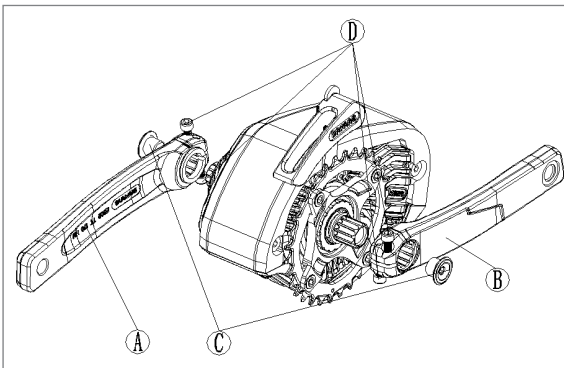

- A Left crank
- B Right crank
- C Screw (for the crank)
- D Hexagonal socket head cap screw M6\*20

Assemble the right crank to the center axle at the right side, lock screw C (for the crank) to the center axle with internal hexagonal wrench at the tightening torque of 1.5N.m; Tighten the 2 M6\*20 screw alternately with internal hexagonal wrench at the tightening torque of 15N.m (Attention: DO NOT tighten the screw one time at one side). Then assemble the left crank with the same method (guarantee the left crank and the right crank are in parallel direction).

## 2.7 External Speed Sensor Installation SR SD02.01

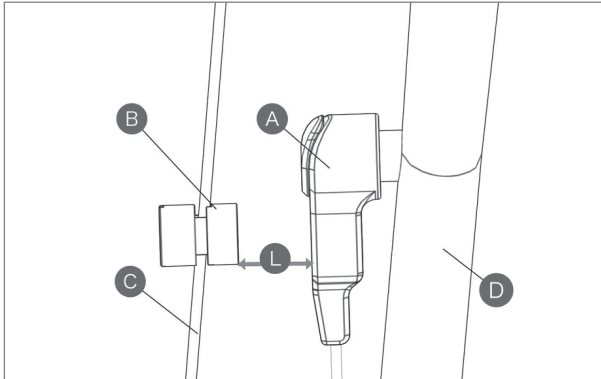

- A** external speed sensor
- B** magnet unit
- C** spoke
- D** chain stay

Before installing the speed sensor, please make sure the gap between the speed sensor and the magnetic unit is between 5 and 25 mm.

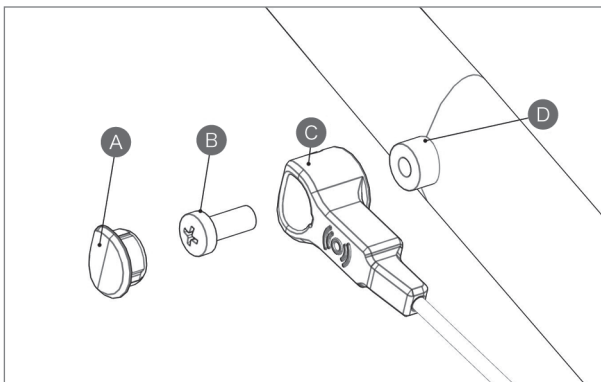

- A** Dust cap  
2301030000003
- B** mounting bolt M5×12
- C** external speed sensor
- D** sensor bracket (chain stay boss)

If the gap is within the specified range, use the mounting bolt to fix the speed sensor.

If the gap is more than 25 mm, please put spacers between the sensor and the chain stay boss to reduce this gap.

Tightening torque: 1.5–2 Nm

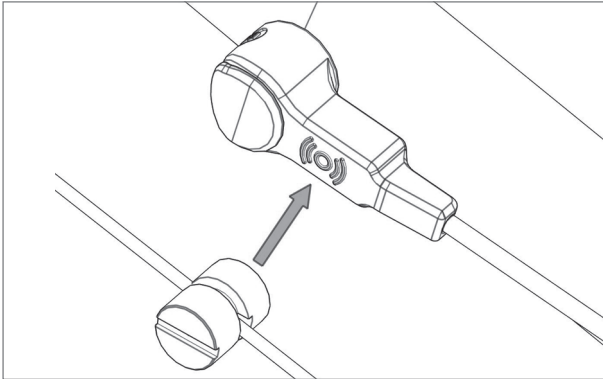

Arrange the speed sensor and the magnet unit as shown in the picture above. When installing the magnet unit, make sure its center is aligned with the center of the speed sensor's induction zone.

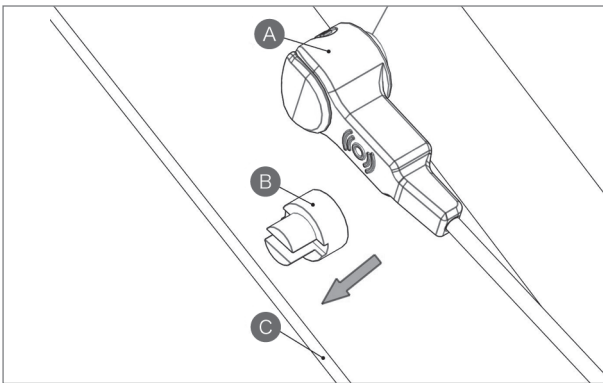

- Ⓐ external speed sensor
- Ⓑ magnet unit  
PS01010702/  
2308040000001
- Ⓒ spoke

Arrange the speed sensor and the magnet unit as shown by the picture above. Mount the magnet unit onto the spoke.

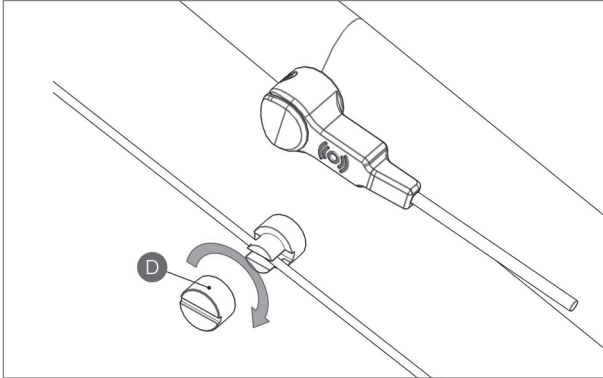

- D Mounting nut of the magnet  
PS01010701/  
2327000000003

Tighten up the mounting nut with a straight slot screwdriver. Tightening torque: 1.5–2 Nm

# 3 LIST OF MATERIALS

---

## 3.1 Drive Unit - MM G520.250

### 3.1.1 Drive Unit Accessories

| Name           | Material No.  | Quantity | Specification |
|----------------|---------------|----------|---------------|
| M8 flat washer | 1401060000196 | 3        | M8            |
| M8 bolt        | 1401280000002 | 3        | M8            |
| M8 Lock ring   | 1401080000127 | 3        | M8            |

### 3.1.2 Motor Cover Accessories

| Name                             | Material No.  | Quantity | Specification |
|----------------------------------|---------------|----------|---------------|
| Motor cover                      | 1333000000021 | 1        |               |
| Motor cover (optional)           | 1333000000020 | 1        |               |
| Bash guard                       | 1333000000023 | 1        |               |
| Bash guard (optional)            | 1333000000022 | 1        |               |
| Hexagonal socket head screw M3×8 | 1401020000268 | 4        | M3×8          |
| Hexagonal socket head screw M5×8 | 1401020000269 | 4        | M5×8          |

### 3.1.3 Chain Wheel Module

| Name                            | Material No.  | Quantity | Specification |
|---------------------------------|---------------|----------|---------------|
| Chain wheel Module A            | 1325070000001 |          | CL-52 mm/32 T |
| Chain wheel Module B (optional) | 1325070000002 |          | CL-52 mm/40 T |
| Lock ring                       | 1334000000002 |          |               |



### 3.1.4 Crank Components

| Name                  | Material No.  | Quantity | Specification |
|-----------------------|---------------|----------|---------------|
| Right straight crank  | 1327070000002 | 1        | 170 mm        |
| Left straight crank   | 1327070000001 | 1        | 170 mm        |
| Crank mounting screws | 1401020000266 | 2        |               |

## 3.2 Cables

| Name            | Material No. | Quantity | Specification      |
|-----------------|--------------|----------|--------------------|
| Front BUS cable |              | 1        | according to order |
| Rear BUS cable  |              | 1        | according to order |
| Battery cable   |              | 1        | according to order |
| Headlight cable |              | 1        | according to order |
| Taillight cable |              | 1        | according to order |

# NOTES

---



